



International
Internal Lining
TECHNICAL MANUAL

PRIMAaquaTM **PRIMA**luxTM **PRIMA**CTUTM

CERTIFIED TO:
AS/NZS 2908.2



Introduction

Saint-Gobain Prima Sdn Bhd offers alternative premium quality building products under “PRIMA” brand for use in residential houses and commercial buildings.

PRIMA cellulose fibre reinforced cement flat sheets are autoclaved single faced building boards manufactured by Saint-Gobain Prima Sdn Bhd in accordance with AS/NZS 2908.2 Cellulose-cement products, Part 2: Flat Sheets.

Accredited with MS ISO 9001:2000, Saint-Gobain Prima delivers products with consistent premium quality, backed with excellent customer service.

PRIMA building boards are the new generation of Cellulose Fibre Reinforced cement boards, offering consistent performance and long lasting durability.

Contents



Internal Product Range

- Basic Composition
- Moisture Content
- Building Code Compliance
- Standard Sizes and Mass

PRIMA*aqua*[™]

Internal Lining

- Product Description
- Installation Instructions
- PRIMA***aqua*[™] Wall Lining
- PRIMA***aqua*[™] Ceiling and Soffit
- Joints and Corners (Untiled Walls and Ceilings)
- Intersections
- Wet Area Waterproofing Systems
- Tiling to **PRIMA***aqua*[™] Wall
- Painting and Wall Covering

PRIMA*lux*[™]

Wall and Ceiling Linings

- Product Description
- Installation Instructions
- PRIMA***lux*[™] Wall Lining
- PRIMA***lux*[™] Ceiling Lining
- PRIMA***lux*[™] Exposed Beam Ceiling
- Joints and Corners
- Finishes

PRIMA*CTU*[™]

Substrate for Tiles

- Product Description
- Installation Instructions
- Expansion Gap and Joint
- Tiling and Grouting

Working Instructions

- Delivery, Handling and Storage
- Cutting Methods
- Notching
- Penetrations
- Maintenance
- Working safer with PRIMA Products

Internal Product Range

PRIMA interior product range includes:

- **PRIMA***aqua*[™] internal lining
- **PRIMA***lux*[™] wall and ceiling linings
- **PRIMA***CTU*[™] substrate for tiles

Basic Composition

Basic ingredients of the products are Portland cement, finely ground sand, quality pulp from NZ and water.

Moisture Content

Moisture content at EMC is approximately 7% and at saturation is 33%.

Note: Where values are stated at EMC, the ambient temperature is 27°C ± 2°C and relative humidity is between 65% - 95%

Building Code Compliance

The requirement set out in the Building Code and local Building Regulatory Authority must be checked and verified prior to the commencement of work to ensure their compliance.



Fire Performance

PRIMA*aqua*[™], **PRIMA***lux*[™] and **PRIMA***CTU*[™] have been tested by CSIRO Australia to AS 1530.3 and have achieved the following indices.

Early Fire Hazard Indices

Ignition Index	0
Spread of Flame Index	0
Heat Evolved Index	0
Smoke Developed Index	0-1

PRIMA*aqua*[™] has been tested by CSIRO to AS/NZS 3837 and is classified as a Group 1 material in accordance with specification A2.4 and C1.1 Oa of the Building Code of Australia (BCA).

PRIMA*aqua*[™] is non-combustible based on test by CSIRO according to AS 1530 Part 1 "Combustibility Test For Materials" Standard.

PRIMA*aqua*[™], **PRIMA***lux*[™] and **PRIMA***CTU*[™] are deemed incombustible in accordance with BCA.

Appraisals

The **PRIMA***aqua*[™] cellulose-cement flat sheets as manufactured by Saint-Gobain Prima Sdn Bhd are suitable for use as internal and external ceiling linings, eave linings and internal wall linings in dry or wet areas that are not subjected to direct sunlight, rain or snow when the conditions listed in CSIRO Technical Assessment 244 are fulfilled.

OPUS International Consultant, New Zealand has determined the compliance of **PRIMA***aqua*[™] to AS/NZS 2908.2 Cellulose-Cement Products. Part 2: Flat Sheets.

Serviceability Life

The performance of **PRIMA** products is limited only by the durability of the supporting structure and the materials used in the installation. When installed and maintained as per good building practice and specifications described in this manual, **PRIMA** products are expected to have a minimum serviceability life of 50 years*.

**Appraised by BRANZ based on New Zealand Building Code*

Internal Product Range

Standard Sizes and Mass

PRIMA ^{aqua} ™ Wall and Ceiling Linings (Flush Finish Board)				
Appearance	Smooth sanded surface. Square Rebate at 2 long edges.			
Mass at EMC	<ul style="list-style-type: none"> • 6.0mm sheets- 8.5kg/m² • 9.0mm sheets- 12.5kg/m² 			
Density at EMC	• Density at EMC is 1390kg/m ³			
Length (mm)	Width (mm)			
	900	1200		1350
	6.0	6.0	9.0	6.0
1800		✓		
2400	✓	✓	✓	✓
2700		✓	✓	
3000	✓	✓	✓	✓
3600	✓	✓		✓
4200		✓		✓



PRIMA ^{lux} ™ Wall and Ceiling Linings		
Appearance	Smooth sanded surface. Arrised edge on all 4 sides.	
Mass at EMC	<ul style="list-style-type: none"> • 4.5mm sheets- 6.5kg/m² • 6.0mm sheets- 8.5kg/m² 	
Density at EMC	• Density at EMC is 1390kg/m ³	
Length (mm)	Width (mm)	
	900	1200
	6.0	6.0
1800	✓	✓
2400	✓	✓
3000	✓	✓



PRIMA ^{CTU} ™	
Appearance	Smooth surface with pre-marked. fixing positions, square edge.
Thickness	6.0mm
Width	900mm, 1200mm
Length	1800mm
Mass at EMC	8.5kg/m ²



Note:

1. Other sizes may be available upon special order and may be subject to special conditions.

2. The mass per unit area given should NOT be used for calculating the weight for transportation purposes. For packing details, contact our office or our nearest agent in your area.



Product Description

PRIMA^{aqua}™ sheets are manufactured to nominal 6.0mm and 9.0mm thickness and are suitable for use as internal wall and ceiling linings, soffit linings as well as wet area applications where sheets are subjected to severe or intermittent wetting.

PRIMA^{aqua}™ sheets are manufactured with a sanded and sealed surface, and its long edges are square rebated, for seamless, and flush set joint.

PRIMA^{aqua}™ has a typical moisture movement of 0.06% - from Equilibrium Moisture Content to saturation. This feature allows the sheets to be flush set, without fear of cracks.

Installation Instructions

Sheet Thickness Selection

The selection of sheet thickness should be based on the following criteria: -

- For general residential construction and ceiling applications - 6.0mm PRIMA^{aqua}™.
- For construction where high impact resistance may be desirable, e.g: Hotels, Schools, Hospitals and Shopping Centres - 9.0mm PRIMA^{aqua}™.

Framing Specification

PRIMA^{aqua}™ can be applied to timber or steel framing. Framing timber must comply with AS 1684 - Residential Timber-Framed Construction. To minimize shrinkage, it is preferable to use kiln-dried framing timber.

Steel frame must comply with AS3623; Domestic metal framing. Steel framing must be fabricated from light gauge steel of a minimum 0.55mm to 1.60mm base metal thickness. Use only cold-formed steel sections. The use of hot rolled sections is not recommended due to the excessive thermal differential movement.

Stud face width must be at least 38mm.

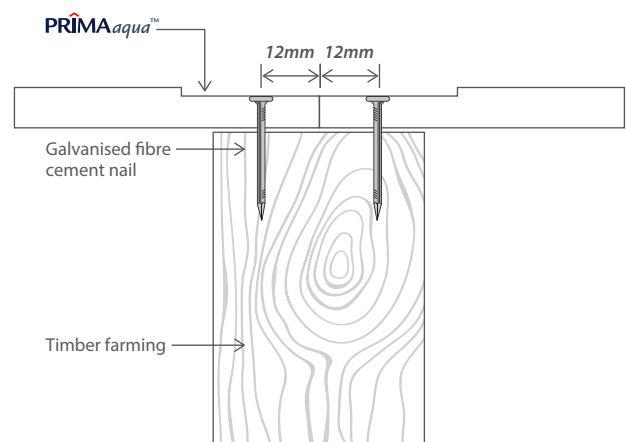

Figure 1: Fixing Timber Support

PRIMA^{aqua}™ Internal Lining

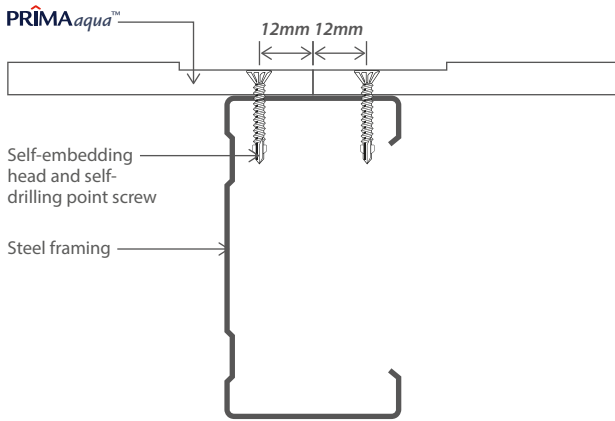

Figure 2: Fixing to Steel Support

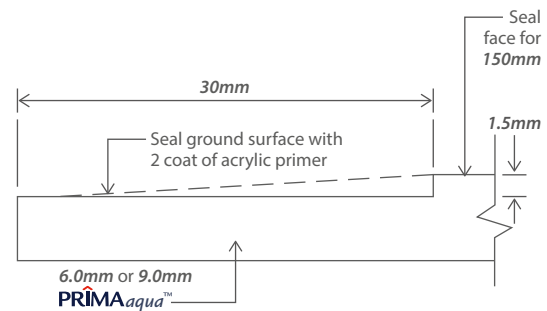





Figure 3: Square Rebated Edge

Fasteners

Fixing to Timber	Fixing to Steel Frame 0.55mm to 0.75mm Base Metal Thickness	Fixing to Steel Frame 0.75mm to 1.6mm Base Metal Thickness
Galvanised Fibre Cement Nails	Self-embedding Head, Self-drilling Screws	Self-embedding Head, Self-drilling "Wing Tek's" Screws
		
<ul style="list-style-type: none"> • 2.8mm \varnothing x 30mm for fixing 6.0mm PRIMA^{aqua}™ • 2.8mm \varnothing x 40mm for fixing 9.0mm PRIMA^{aqua}™ 	<ul style="list-style-type: none"> • 8 gauge - 18 x 20mm for fixing 6.0mm PRIMA^{aqua}™ • 8 gauge - 18 x 30mm for fixing 9.0mm PRIMA^{aqua}™ 	<ul style="list-style-type: none"> • 8 gauge - 18 x 20mm for fixing 6.0mm PRIMA^{aqua}™ • 8 gauge - 18 x 30mm for fixing 9.0mm PRIMA^{aqua}™

Note:

1. Screw heads must be embedded 0.5mm below sheet surface.
2. Drive nail heads flush with board surface.
3. Screws must have adequate corrosion resistance coating.
4. All nails shall comply with AS 2334 : Steel nails Metric Series or equivalent standards.
5. All screws shall comply with AS 3566 - Self-drilling Screws - for the building and construction industries or equivalent standard.
6. Fastener fixing points may be patched with joint compound and then sanded with 120 grit sandpaper upon drying.

On-site Sheet Edge Rebating

Best result on PRIMA^{aqua}™ joint can be obtained with square rebated edges. At times it may become necessary to form a rebated edge on a building site. This can be achieved using an electric grinder equipped with an appropriate carborundum blade. Ensure the ground edge retains at least 4.5mm thickness for 6.0mm sheet and 7.5mm for 9.0mm sheet.

PRIMA^{aqua}™ Wall Lining

Sheet Orientation

PRIMA^{aqua}™ sheets may be installed vertically or horizontally. Generally, sheets are placed to minimize the number of joints. Horizontal sheeting is more convenient for residential construction. When fixing horizontally, sheets must be laid in staggered or brick pattern. Sheet joints must not coincide with sides of openings. Refer to Figure 4.

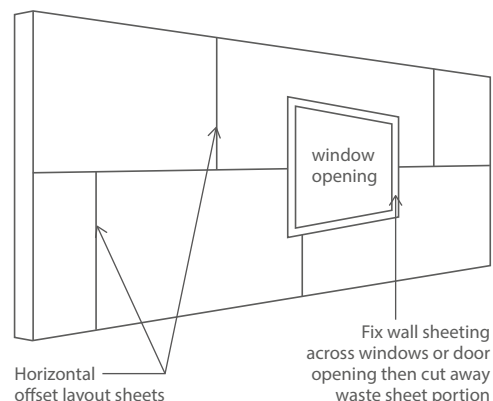

Figure 4: Sheet Layout at Openings

Framing Construction

Framing must be constructed with studs at maximum 600mm centres with continuous top and bottom plates. Framing stability must not be dependent on lining material. Where necessary, provide noggings for framing stability.

Nail / Screw Fixing

Fixings are to be installed at 200mm maximum centres to all sheet edges and all intermediate framing members. Fixings are to be a minimum of 12mm from sheet edges and 50mm from corners of sheet. Commence fixing each sheet from centre working outward to ensure sheeting is installed firmly against the framing. Do not fix sheets to top and bottom plates and noggings, unless wall is to be tiled.

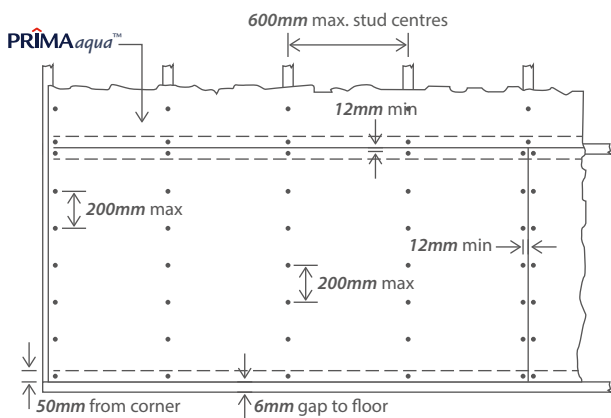

Figure 5: Horizontal Sheet Fixing (Untiled Wall)

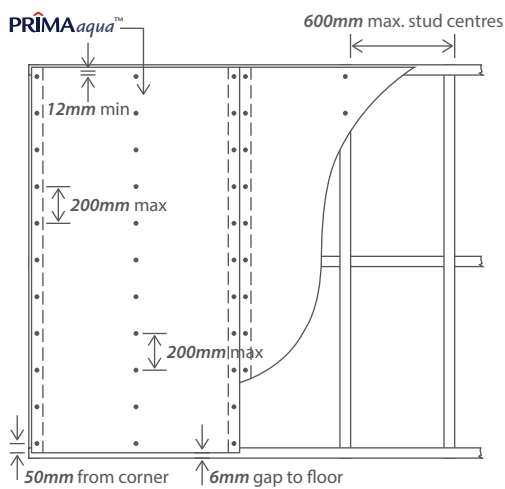

Figure 6: Vertical Sheet Fixing (Untiled Wall)



Adhesive and Fastener Fixing Method (Untiled Walls)

This fixing method is only suitable for untiled wall applications. Install PRIMA^{aqua}™ as follows :-

1. Ensure framing surface and the reverse side of PRIMA^{aqua}™ is free from any dust or other contaminants.
2. Apply approximately 25mm diameter x 15mm thick daubs of wallboard adhesive at intermediate framing member surface at 250mm centres maximum.
3. Nail or screw the sheet ends at 200mm centres and ensure sheet's long edges are fixed to each framing member.
4. Fastener fixing point must not coincide with daubs of adhesive.
5. Provide temporary blocks at sheet centre and allow adhesive to cure prior to removing the temporary blocks. (Not required for ceiling application).

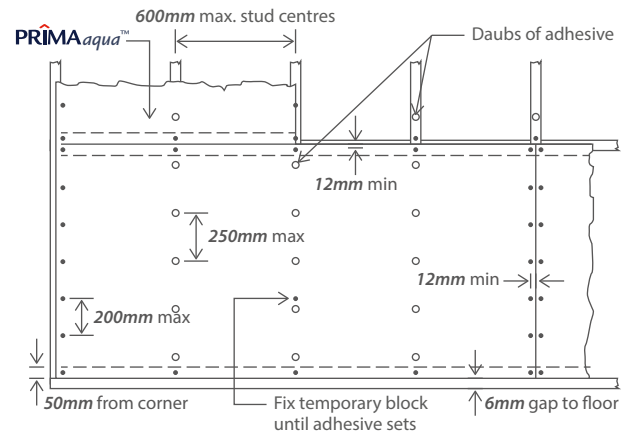

Figure 7: Adhesive and Fastener Fixing (Untiled Wall)

PRIMA^{aqua}™ Ceiling and Soffit

Framing Construction and Sheet Layout

Ceiling joists or battens must be spaced not exceeding 600mm centres. Provide intermediate framing where necessary. Intermediate framing does not necessarily coincide with sheet edges.

PRIMA^{aqua}™ sheets must be laid with the long dimension at right angles to the supporting structure, in a staggered or brick pattern.

Sheet Fixing

Nail or screw PRIMA^{aqua}™ as depicted in Figure 8. When using wall adhesive in conjunction with nails and screws, apply about 25mm diameter x 15mm thick daubs of adhesive at 250mm centres as shown in Figure 9. Use double nailing at sheet centre when fixing PRIMA^{aqua}™ as ceiling lining.

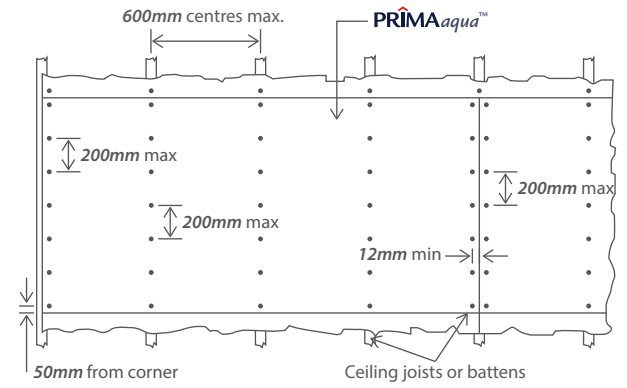

Figure 8: PRIMA^{aqua}™ Ceiling - Nail or Screw Fixed

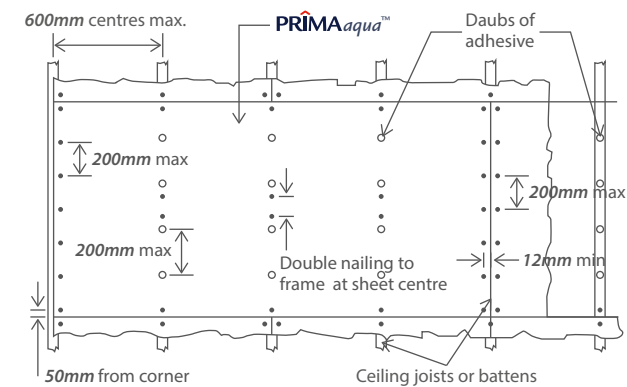

Figure 9: PRIMA^{aqua}™ Ceiling - Fastener and Adhesive Fixed

Joints and Corners (Untiled Walls and Ceilings)

Flush Jointing

PRIMA^{aqua}™ sheets may be loosely butt jointed. Gap between sheets should not exceed 3mm. Sheet joints must occur at the centre line of supports.

PRIMA^{aqua}™ joints may be flush set with proprietary plaster compounds. The jointing method is as follows:-

1. Ensure that the sheet joint is free from dust, grease and / or any contaminants.
2. Prepare the joint compound as per the manufacturer's recommendation.
3. Apply the first layer of joint compound onto the sheet joint to cover the joint recess and embed the perforated paper jointing tape into the bedding material. Cover the tape with a thin layer of the joint compound and allow it to dry.
4. Apply the second coat of joint compound, spreading to approximately 200mm wide and allow to dry.
5. Apply the third coat of joint compound, feathering out to approximately 270mm wide.
6. When topping compound is completely dry, sand off with 120 grit sandpaper prior to applying finishes.

Notes:

1. Ensure that the perforated paper jointing tape is thoroughly embedded to eliminate any air bubbles being trapped between the tape and the jointing compounds.
2. Most Plasterboard Jointing and Topping Compounds are compatible with, and suitable for flush jointing PRIMA^{aqua}™.

Movement Joints

At the movement joint, wall or ceiling construction must have total separation of the framing and lining sheets. A minimum of a 5mm gap must be provided. If an expansion joint kit is used, a minimum gap of 15mm is required. Tiles or any nonflexible finishes must not bridge over movement joint. Refer to Figure 11 and Figure 27.

Movement joint must be provided as follows:-

- 7.2m centres for untiled walls and ceiling
- 4.8m centres for tiled walls

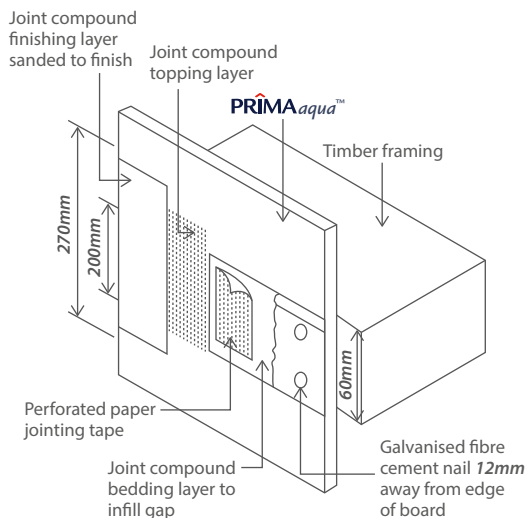

Figure 10: Flush Joint Detail (Untiled Wall and Ceiling)

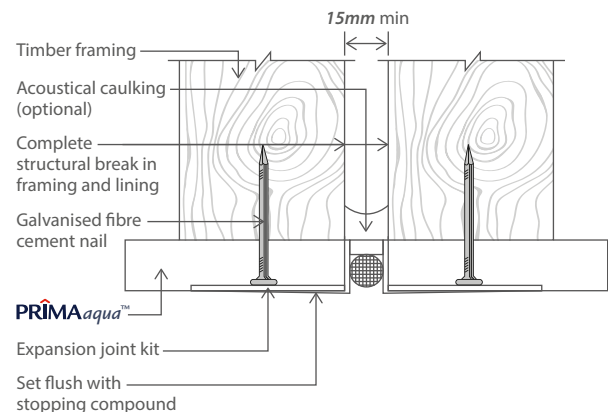

Figure 11: Movement Joint Detail (Untiled Wall and Ceiling)



Internal Corner

Apply bedding compound to both faces of the internal corners to a width of approximately 60mm from the corner. Fold the perforated paper tape to form a 90 degree angle, embed the tape into the compound and cover the tape with a thin layer of compound. Allow the compound to dry thoroughly. Apply the second coat of bedding compound and allow to dry thoroughly. Apply a coat of topping compound feathering out approximately 200mm from the internal corner. Allow to dry thoroughly and sand with 120 grit sandpaper. Refer to Figure 12.

External Corners

PRIMA^{aqua}™ external corners may be finished with proprietary external corner beads. For wet area applications, use only PVC corner angles. Trowel a layer of joint compound onto the external corner beads to a width of 150mm and allow it to dry. Spread the second coat to 250mm from the corner. Upon drying of the second coat, spread the final coat of the topping compound to approximately 300mm from the edge. Refer to Figure 13.

Note: Finishing coat of joint compound must be sanded with 120 grit sandpaper prior to application of paint or wall covering.

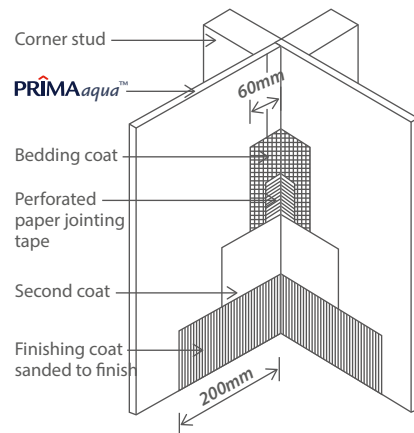

Figure 12: Internal Corner Detail

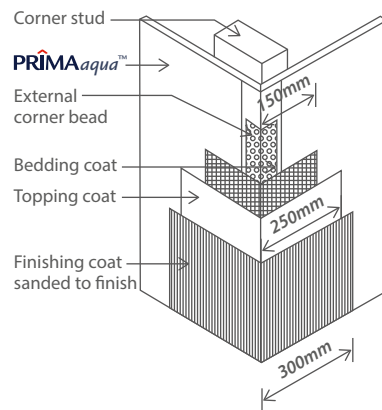

Figure 13: External Corner Detail

Intersections

Wall to Ceiling and Floor

The intersection between PRIMA^{aqua}™ wall and ceiling may be finished with plaster cornice, timber moulding or PVC angle. PRIMA^{aqua}™ wall to floor intersection may be finished with suitable skirting. Refer to Figure 14

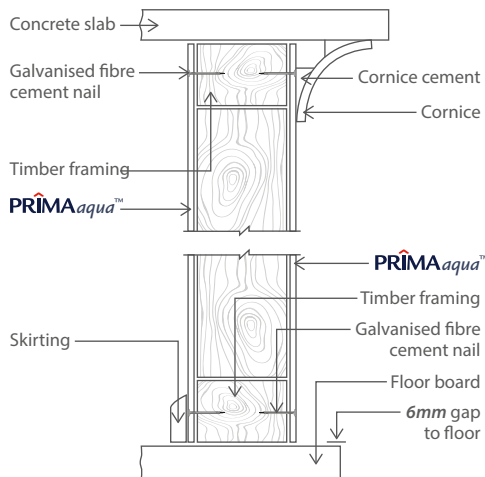

Figure 14: Junction of Wall to Ceiling & Floor

Wall Abutment (Masonry Wall)

Where PRIMA^{aqua}™ walls intersect with masonry walls, a flashing material should be installed to isolate stud wall from moisture migration through masonry. Refer to Figure 15.

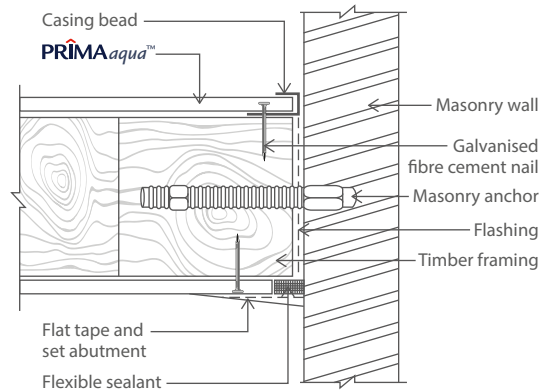

Figure 15: Detail at Masonry Wall Abutment

Wet Area Waterproofing Systems

Wet area waterproofing should comply with Australian Standard, AS 3740: Waterproofing of wet areas within residential buildings, or equivalent. Construction must be in accordance with good building practices and fulfill the local building regulations.

General Wet Area

Provide perimeter flashing at floor-to-wall intersections in all general wet areas such as kitchen, laundries and bathroom, other than shower. Flashing must extend a minimum of 40mm from finished floor level. Alternatives of perimeter flashing are shown in Figure 16 to Figure 18.

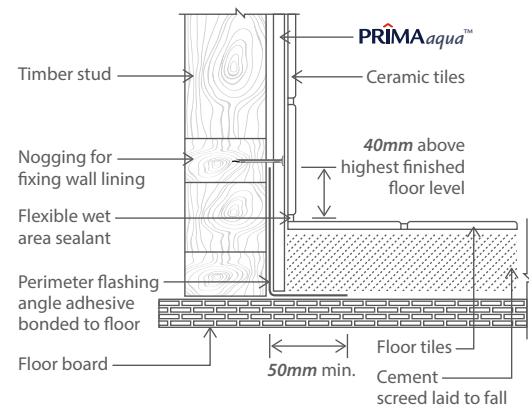

Figure 17: Angle Perimeter Flashing

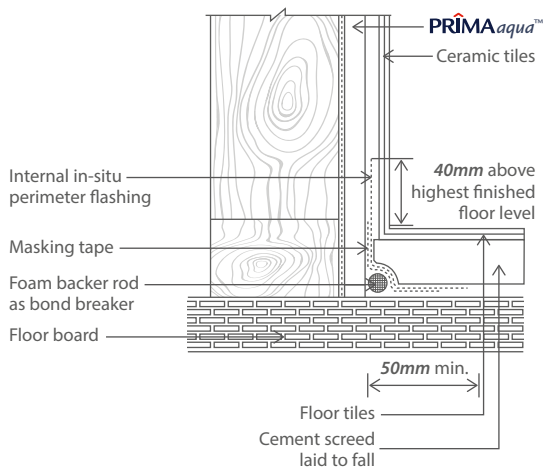

Figure 16: Cast In-situ Perimeter Flashing

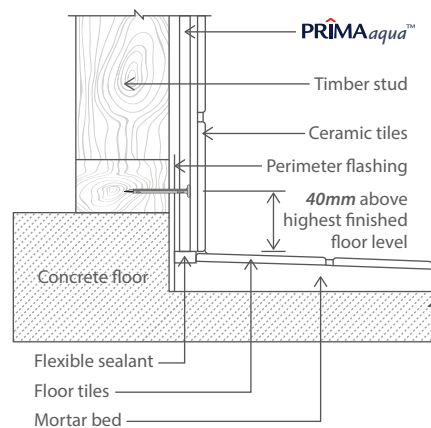

Figure 18: Flashing at Concrete Floor Slab

In-situ Internal Shower Tray

Cast In-situ Internal Membrane System must be constructed as follows: Refer to Figure 19 and Figure 20.

1. Floor must be completed prior to installation of wall lining.
2. Provide galvanized mild steel angles with minimum leg of 40mm at corner studs.
3. Fix PRIMA^{aqua}™ as per fixing instructions.
4. Seal the gap between PRIMA^{aqua}™ edges and the floor with compatible flexible acrylic sealant or its equivalent.
5. Construct a bond breaker at wall-to-floor intersections. This can be done by adhering 13mm diameter backer rod to the intersection corner by means of self-adhesive paper tape.
6. Apply the waterproofing membrane to the floor and PRIMA^{aqua}™ wall. Waterproofing on PRIMA^{aqua}™ must extend a minimum of 150mm above the finished bathroom floor level or 25mm above the highest possible water level. Refer to Figure 19 and 20. In all cases, refer to membrane manufacturer for details.
7. Extend waterproofing membrane to form angle flashing (min.75mm legs) along the vertical corner. Flashing must also be applied at all sheet joints.
8. Lay the cement screed to the required gradient.
9. Fix tiles as specified in the 'WALL TILING PROCEDURE' section on page 14.

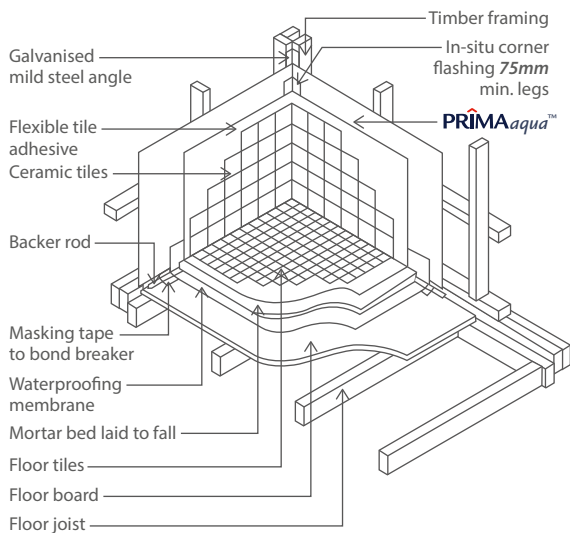

Figure 19: Cast In-situ Internal Membrane

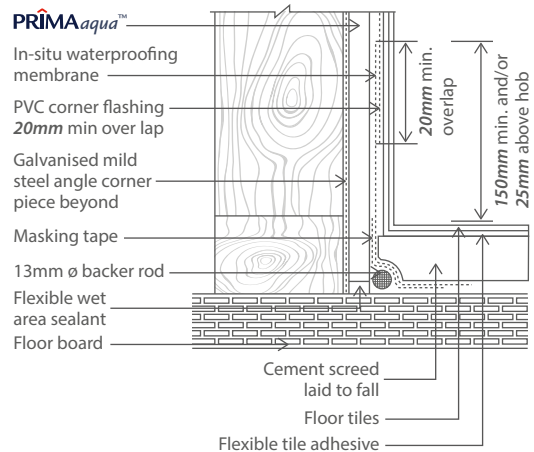

Figure 20: Detail of Cross-section at Wall-to-Floor



Pre-formed Shower Tray

The shower tray installation may be as per Figure 21. Provide 6mm gap between the sheet and shower tray. Seal gap with waterproof flexible acrylic gap sealant or silicon sealant.

Detail at Pipe Penetration

Provide a 6mm clearance around pipe penetrations. Seal gap with acrylic gap sealant and silicone sealant. Refer to Figure 22.

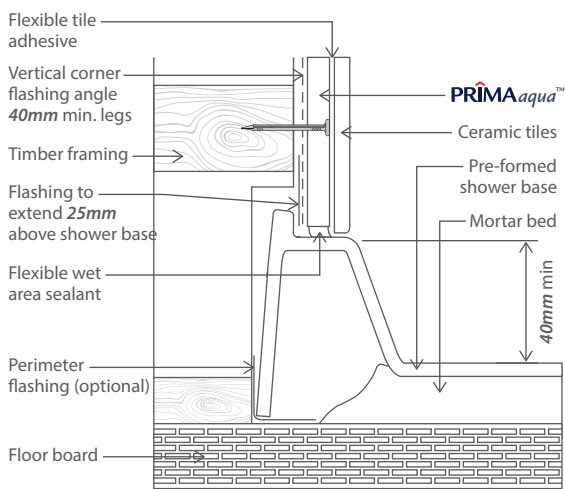

Figure 21: Shower Recess Detail

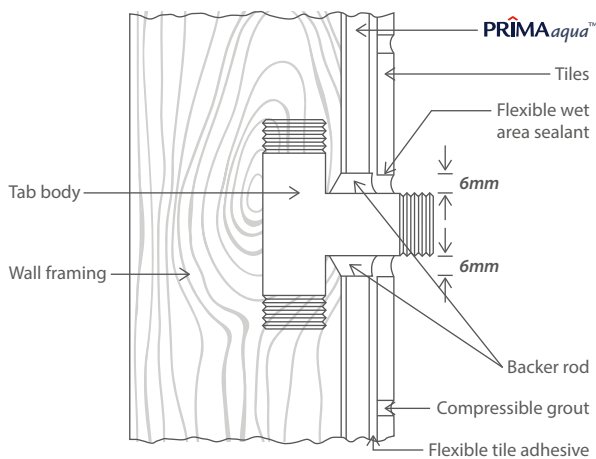

Figure 22: Pipe Penetration Detail



Tiling to PRIMA^{aqua}™ Wall

PRIMA^{aqua}™ wall lining is an excellent substrate for tiling. Flexible tile adhesive must comply with AS 2358 - Adhesive For Fixing Ceramic Wall Tiles. Sheets to be tiled must not be fixed using wallboard adhesive.

For general purpose application of ceramic tiles up to 6.0mm thickness, framing must be constructed with studs at 600mm maximum centres and noggings at 1200mm maximum centres.

PRIMA^{aqua}™ sheet must be fixed to studs, noggings, top and bottom plates. Refer to Figure 23.

To cater for increased loadings in heavy duty installations and where tiles exceed 6.0mm in thickness, studs must be spaced at 400mm maximum centres and noggings at 600mm maximum centres.

Installation of tiles with a mass of 20kg/m² or more may require specific detailing for the provision of adequate structural support. Generally the bottom edge of tiles must be supported by a metal angle which has been fixed to the bottom plate prior to commencement of tiling. For heavy tile installations, 9.0mm thick PRIMA^{aqua}™ must be installed as a substrate.

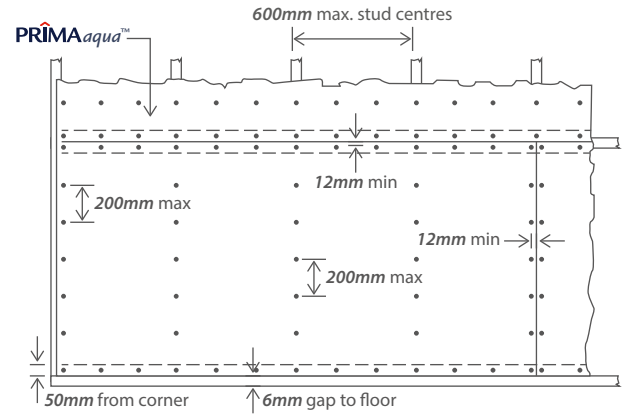

Figure 23: Horizontal Sheeting (Tiled Wall)





Wall Tiling Procedure

1. Ensure that the board is free from dust or grease. Wipe board surface with damp cloth if necessary.
2. Mark the height of the proposed tiled wall.
3. Estimate the number of tile courses required.
4. Indicate the bottom edge of the first course of full-sized tiles.
5. Apply flexible tiling adhesive to the board surface with a notched trowel. Spread the adhesive not more than 1m² at a time. Refer to the adhesive manufacturer's recommendations.
6. Fix tiles to PRIMA^{aqua}™ with an allowance of approximately 2mm gap between each tile. Use tile spacer to achieve consistent gap at tile joint.
7. Apply adequate pressure to the tile to ensure that the back face of the tile is covered with the tiling adhesive.
8. The bottom course is normally fixed last.

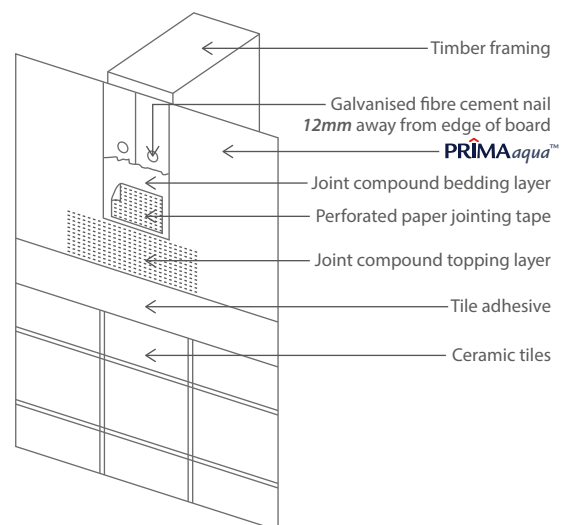

Tiled Joint

Sheet joint to be tiled must not be finished with topcoat joint compound. Refer to Figure 24.

Figure 24: Tiled Joint Detail

Tiled Vertical Corners

Where internal and external vertical corners are to be tiled, seal junctions of sheets with flexible wet area sealant. Use mould-resistant silicone to seal tile corner joints (colour matched with tile or grout). Refer to Figure 25 and Figure 26.

Tiled Movement Joint

When tiled walls exceed 4200mm in their dimensions (i.e. length or height), a movement joint must be provided. Tiles must not bridge over a movement joint and construction must be detailed as shown in Figure 27.

Painting and Wall Covering

The smooth surface of PRIMA^{aqua}™ is ideal for quality acrylic-based paint. Generally, a minimum of two coats is required. Coating should be of a vapour permeable type. Other types of coating such as polyurethane or epoxy paints are also suitable. In all cases, coating manufacturer's recommendations should be adhered to. PRIMA^{aqua}™ will also accept decorative wall coverings without any special surface preparation. Alternatively, PRIMA^{aqua}™ wall linings may be finished with ceramic, marble or granite tiles. Refer specific section on PRIMA^{aqua}™ tiling procedure.

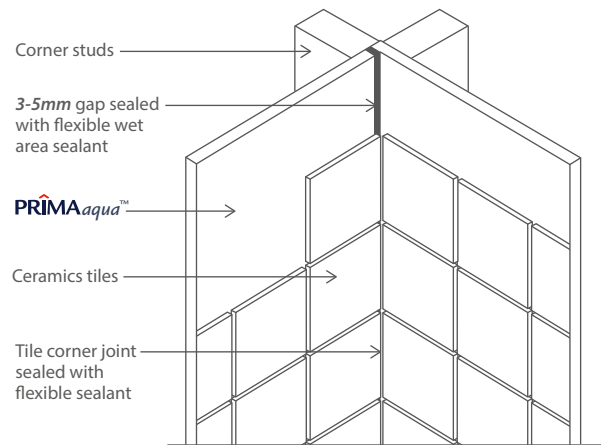

Figure 25: Tiled Internal Corner

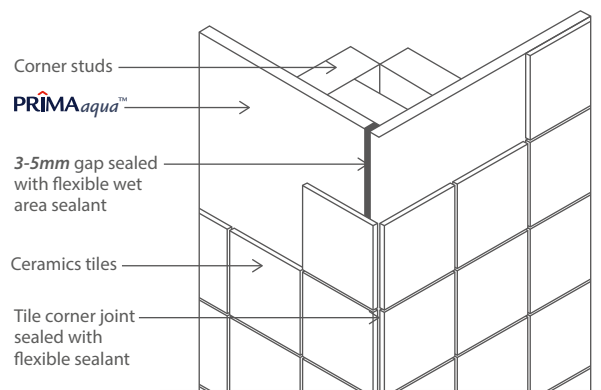

Figure 26: Tiled External Corner

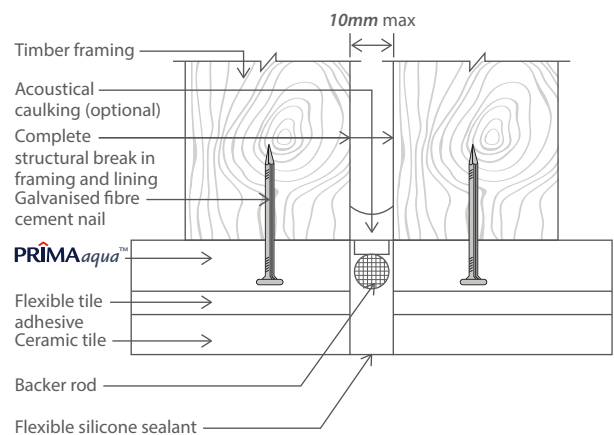

Figure 27: Tiled Expansion Joint



Product Description

Manufactured in nominal thicknesses of 4.5mm and 6.0mm, is designed specifically for wall and ceiling lining applications where a superbly flat and smooth surface coupled with elegantly designed expressed joints are the criteria.

The surface of PRIMA^{lux}™ is sanded and is available with arrisred edges for neat butt joints or PVC joints.

Installation Instructions

Framing Specification

PRIMA^{lux}™ can be fixed to timber or steel framing. Support framing must be spaced as follows:-

- 4.5mm thick PRIMA^{lux}™ - 450mm max. centres
- 6.0mm thick PRIMA^{lux}™ - 600mm max. centres



Support framing must have at least a 38mm wide face to provide adequate support for PRIMA^{lux}™ sheets. Where necessary, the face width may be increased by providing trim-packing to the side of the support.

Timber framing must comply with AS1684 - Residential Timber-framed Construction. Framing timber should be thoroughly dry and selected to minimize shrinkage when sheets are installed. The use of kiln dried timber is recommended.

Steel framing must be fabricated from light gauge steel of a minimum 0.55mm to 1.6mm base metal thickness. Use only cold -formed steel sections complying to AS 3623 : Domestic Metal Framing. The use of hot rolled sections is not recommended due to the excessive thermal differential movement.

PRIMA^{lux}™ Wall and Ceiling Linings

Fasteners

Fixing to Timber	Fixing to Steel Frame 0.55mm to 0.75mm Base Metal Thickness	Fixing to Steel Frame 0.75mm to 1.6mm Base Metal Thickness
		
2.8mm ϕ x 30mm Galvanised Fibre Cement Nails	Self-embedding Head, Self-drilling Screws 8 gauge - 18 x 20mm for fixing 6.0mm PRIMA ^{lux} ™	Self-embedding Head, Self-drilling "Wing Tek's" Screws 8 gauge - 18 x 20mm for fixing 6.0mm PRIMA ^{lux} ™

Notes:
1. All notes for PRIMA^{aqua}™ fasteners are also applicable.
2. Screw fixing is not suitable for 4.5mm PRIMA^{lux}™.

Fixing Distances

Fixings are to be a minimum of 12mm from sheet edges and 50mm from corner of sheet. The fastener spacings must be as follows:-

Application	Sheet Edges	Elsewhere
Wall Lining	200mm	200mm
Ceiling eaves and soffit	200mm	200mm
Exposed Beam Ceiling	300mm	400mm

PRIMA^{lux}™ Wall Lining

When applied as internal wall linings, PRIMA^{lux}™ may be installed vertically, ensuring sheet joints coincide with the centre of supporting frame as shown in Figure 28.

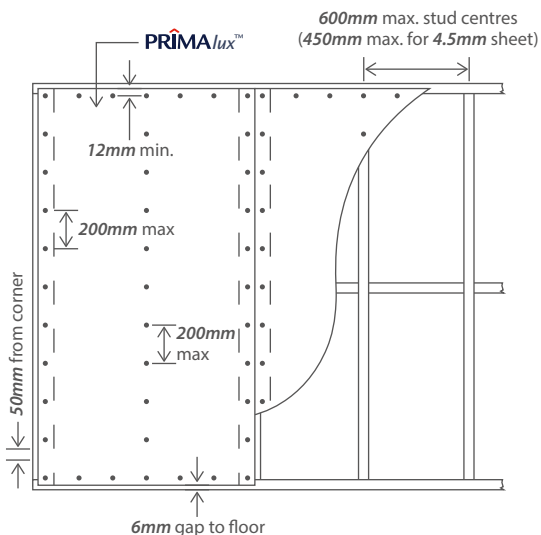

Figure 28: PRIMA^{lux}™ Wall Lining

PRIMA^{lux}™ Ceiling Lining

For ceiling, eaves and soffit lining applications, PRIMA^{lux}™ can be fixed across or parallel to the supporting frame. Sheet butt joints must coincide with centre of supporting frames if PVC jointer is not utilized. Refer to Figure 29 and Figure 30.

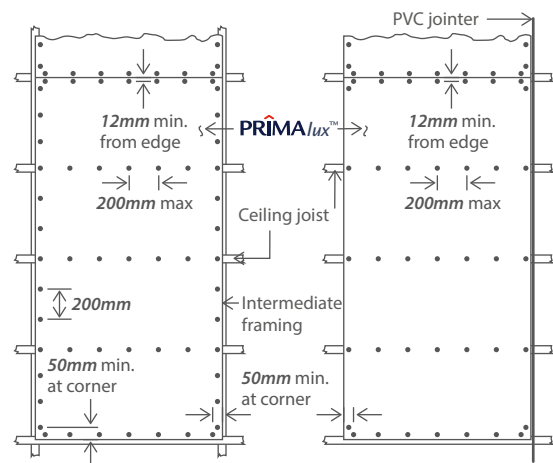

Figure 29: PRIMA^{lux}™ Ceiling Laid Across Joists

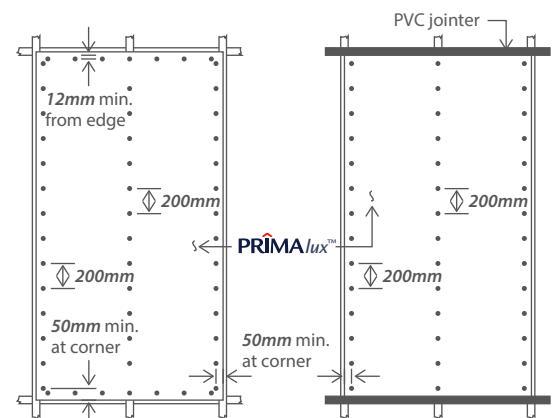

Figure 30: PRIMA^{lux}™ Ceiling Laid Parallel to Joists

PRIMA^{lux}™ Exposed Beam Ceiling

When it is desirable to have the ceiling beams or rafters exposed for aesthetic purposes, PRIMA^{lux}™ serves a better alternative as ceiling lining material. Other than PVC joint and butt joint, PRIMA^{lux}™ may also be flush joined. Sheet edges must be rebated prior to flush jointing. Refer to page 8 for details on flush jointing procedure and ensure the rear surface of the joint is supported. Use only 6.0mm PRIMA^{lux} for flush joint application.

Notes:

1. Sheets should be laid parallel to exposed beams or rafters
2. When rafter spacings exceed 600mm, provide additional support to stiffen the sheets.
3. Check with local building authorities on other requirements, i.e. insulation or sarking, prior to construction
4. When flush jointing, back-block sheet joint to avoid cracking due to support (beams / rafters) sag.

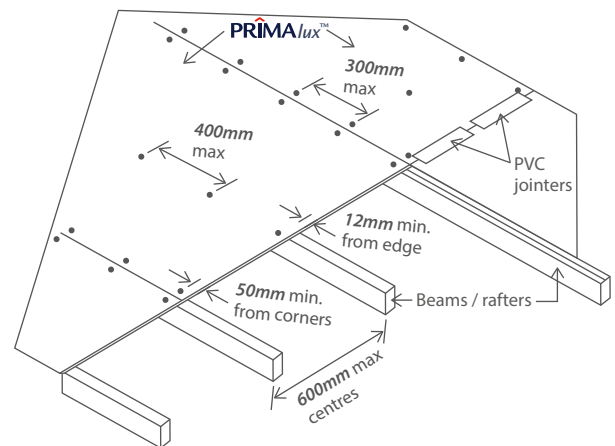

Figure 31: PRIMA^{lux}™ Exposed Beam Ceiling



Joins and Corners

Joins

Alternatives of PRIMA^{lux}™ sheet jointing methods are shown in Figure 32 and Figure 33.

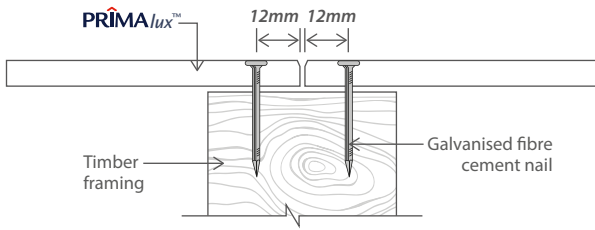

Figure 32: Butt Joint

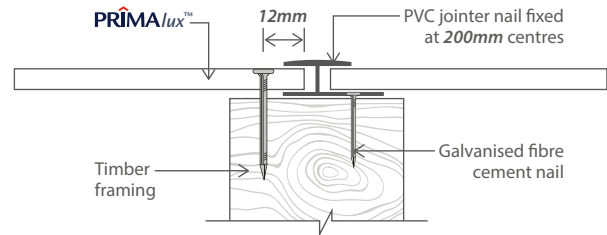

Figure 33: PVC Joint

Corners (Wall Lining)

Internal and external corners may be finished with PVC corner moulds as described in Figure 34 and Figure 35.

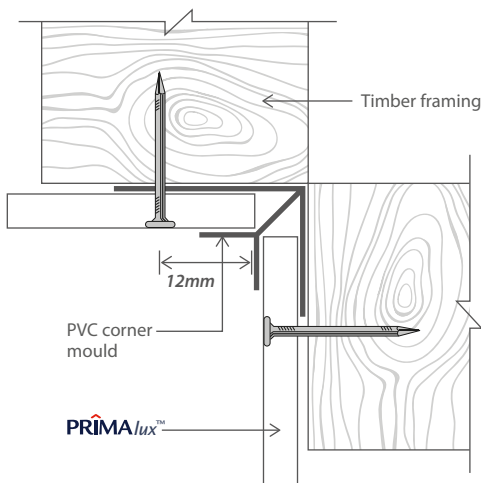

Figure 34: Internal Corner

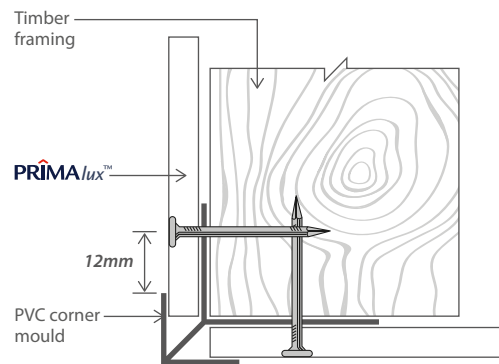

Figure 35: External Corner

Finishes

PRIMA^{lux}™ smooth surface is ideal for quality water-based acrylic paints. Generally, a minimum of two coats is required. Other types of coatings such as polyurethane or epoxy paint are also suitable. In all cases, coating manufacturer's recommendation must be adhered to.



Product Description

PRIMA^{CTU}™ is manufactured to nominal 6.0mm thickness. The material is suitable for use as a substrate for ceramic floor tiles on existing floorboards with minimal surface preparation. The product has preprinted fastener points for ease installation.

Installation Instructions

Preliminary Preparation

Ensure that the underside of the existing floor is adequately ventilated. Check and replace any damaged floorboards and firmly re-nail any loose boards. The floor surface should be reasonably flat. Rough sand any undulations prior to fixing the ceramic tile underlay.

Underlay Orientation

PRIMA^{CTU}™ sheet should be laid in a staggered or brick pattern, across the direction of floorboards. Sheet joints must not coincide with floorboard joints.

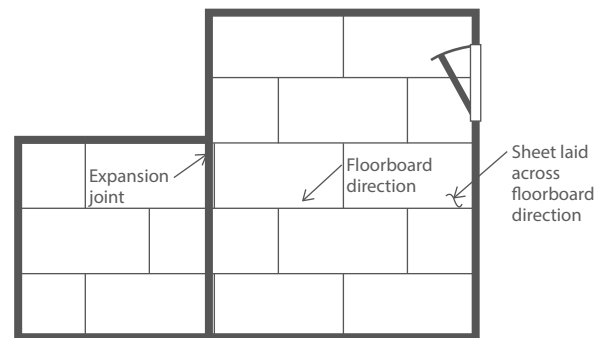
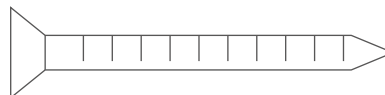

Figure 36: Underlay Orientation

Fixing Method

Nail underlay sheet at the pre-designated fixing locations with 25mm x 2.5mm diameter annular threaded underlay nails. Nail fixing distances must be as follows:



- 12mm minimum from sheet edge
- 50mm minimum from corner
- 75mm maximum centres spacing at perimeter
- 150mm maximum centres spacing at sheet centre

Drive nail head flush with the surface of the underlay sheet. Start nailing from the sheet centre and work outwards toward the sheet ends and edges.

Notes:
For fixing to particleboard or plywood floor, apply wallboard adhesive to the sheet back face with a notched trowel in addition to nail fixing as specified above.

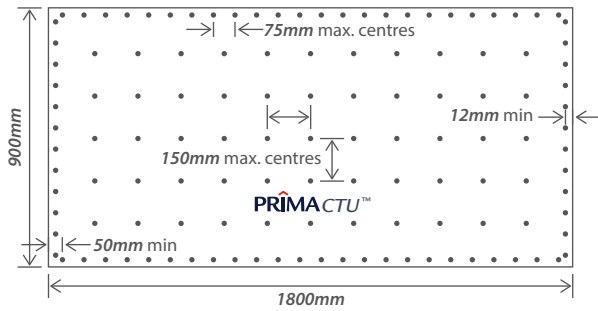

Figure 37: Nail Fixing Locations

Expansion Gap and Joint

Perimeter Expansion Gap

Leave a 3mm gap between sheet edges and wall at the wall-to-floor junction.

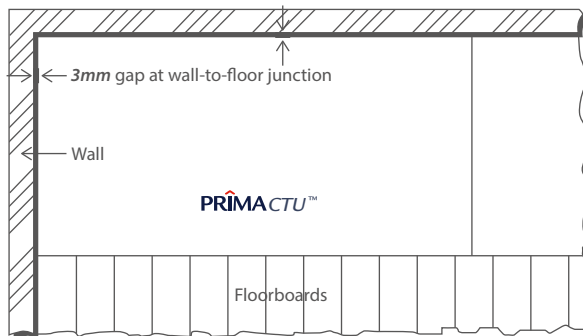

Figure 38: Perimeter Expansion Gap

Expansion Joint

Expansion joints must be provided at 5.0m maximum centres and must always coincide with the structural break joints of the existing floor structure. Do not tile over an expansion joint. Refer to Figure 39.

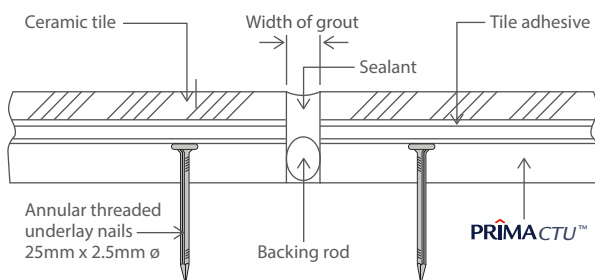

Figure 39: Detail at Expansion Joint



Tiling and Grouting

Use only flexible tile adhesives that comply with AS 2358 - Adhesive For Fixing Ceramic Tiles. Refer to tile adhesive manufacturer for recommendations. Tile grout should be fully compressible.

Tiles should be laid in accordance with acceptable tile laying practice. Provide a minimum of 2 to 3mm gap between each tile.

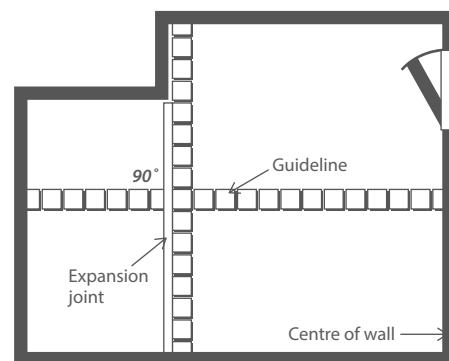

Figure 40: The Laying Guide

Working Instructions

Delivery, Handling And Storage

- To minimize the possibility of on-site damage, sheets should be delivered just prior to installation.
- Always lift sheets vertically, (on-edge) lengthwise.
- Store sheets neatly on a flat surface supported evenly with bearers spaced at 600mm centres maximum, clear of the ground to avoid damage and moisture ingress.
- Store under cover and ensure sheets are dry prior to fixing. Never install damp sheets. Damp sheets must be allowed to dry to equilibrium moisture content (EMC) before fixing.
- Protect edges and corners from damage on site.

Note - Floor loadings should be considered when stacking sheets.



Working Instructions

Cutting Methods

A dust mask and safety glasses should always be worn when cutting, drilling or grinding. Dry cutting with power tools should be performed in a well-ventilated area or open-air situation using a power-saw fitted with dust-extracting attachments.

A circular saw with dust collecting facilities should have carbide-tipped teeth or a carborundum blade.

Scoring and Snapping

Any scribing tool or special tungsten-tipped scoring knife can be used for this method of cutting, refer to Figure 41.

- Score the face of the **PRIMA** board, repeating the action to obtain a depth of about 1/3 of sheet thickness.
- Snap the off-cut upward to achieve cut. If the edge is rough, trim with a rasp.

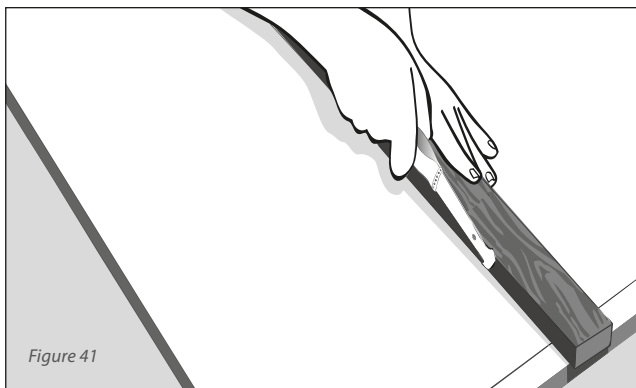

Hand Guillotine

When using a hand guillotine, best results are obtained when the board and the off-cut are both fully supported, refer to Figure 42.

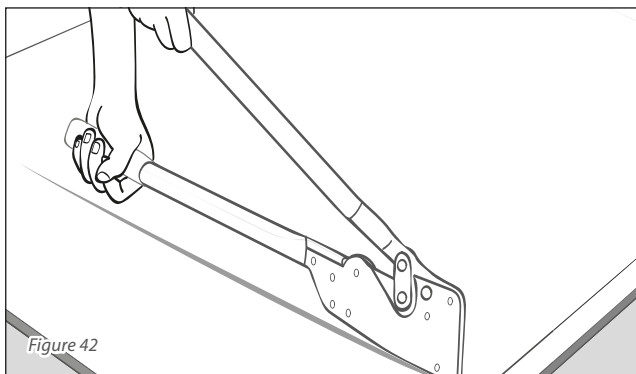

Notching

Use hand saw to cut the sides of the notch. Score along the back of the notch with scoring knife and snap the waste piece upwards, refer to Figure 43.

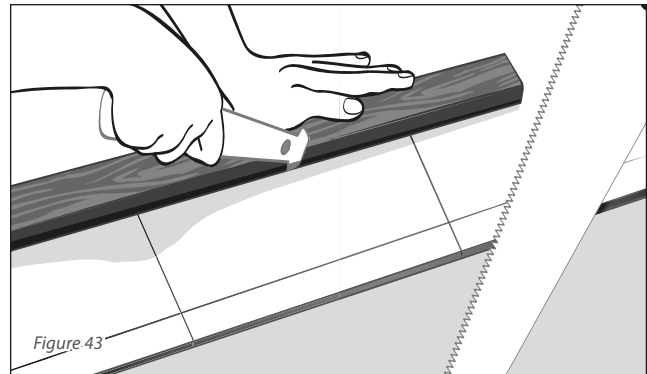

Working Instructions

Penetrations

Round holes may be cut using a power drill with a tungsten tipped hole saw attachment. Alternatively rectangular or circular holes may be formed by using a masonry drill to make a series of smaller holes around the perimeter of the proposed opening, and then tapping out the waste section carefully, refer to Figure 44.

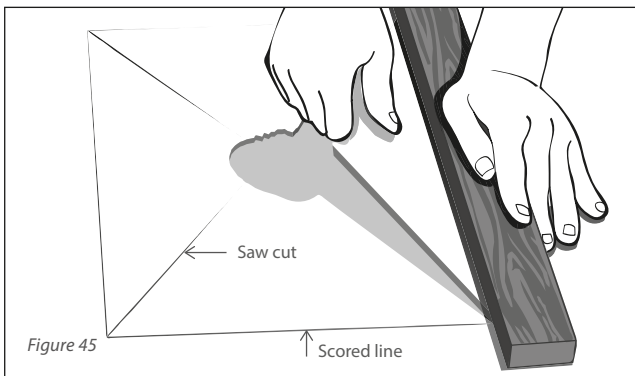
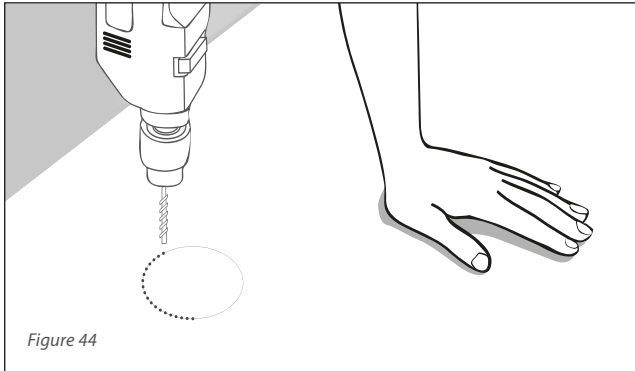

Larger rectangular holes and openings can be made using the following procedure, refer to Figure 45.

- Score the perimeter of the hole using a scoring knife.
- Drill a larger circular hole at the centre of the proposed opening.
- Use a saw to cut from the centre to the corners of the proposed opening.
- Hold a straight edge or a piece of wood along the scored line and snap the waste piece upwards.

Maintenance

Periodic maintenance of the coating and finishes must be performed as specified by the manufacturer. The jointing systems should also be inspected periodically during the life of the building. All joints and sealant must be checked for cracks to prevent the intrusion of water. Make good any defects in accordance with the systems outlined in this manual and good building practices.

Working Safer With Prima Products

- Always work in a well-ventilated area.
- Dust extraction equipment should be fitted to all power cutting tools.
- Wear safety goggles conforming to AS 1337.
- Wear protective clothing.

Warning

Breathing dust from silica based products such as fibre cement can be hazardous over an extended period of time. Always use a mask, protective equipment and clothing that complies with the latest regulations of Occupational Safety and Healthy (OSH) or Workplace Health and Safety.





AS/NZS
2908.2

ASTM
C1186

Fire Resistance
AS 1530.3

Termite Resistance -
tested by CSIRO



CERTIFIED TO ISO 9001:2008
CERT. NO. : AR0430



CERTIFIED TO ISO 14001:2004
CERT. NO. : ER0642



Termite Resistant



Fire Resistant



Water Resistant



Weather Resistant



Environmentally
Friendly



Superior Paint
Adhesion



High Workability



Aesthetically
Pleasing



50 Years
Durability

For more information, please contact us at:



SAINT-GOBAIN PRIMA SDN BHD (579898-W)

Level 19, Tower 5, Avenue 7 The Horizon,
Bangsar South City, No. 8, Jalan Kerinchi,
59200 Kuala Lumpur, Malaysia

General Line 1: +603 7781 1977 | General Line 2: +6012 781 1797

www.primafibreceement.com | www.saint-gobain.my

[f](#) [in](#) [v](#) [@](#) [d](#) saintgobainprima